



Toyota Land Cruiser 70 Series

January 2007 Production Onwards

ACRYLIC BONNET PROTECTOR

Installation Instructions



Accessory Part No. 10966

Installation Time: Approx. 30 mins

Place these instructions in vehicle's glove box after installation is complete

Care Instructions:



Do not slam bonnet.



Clean Bonnet Protector with a mild detergent and water solution.











Do not use automatic car wash.



Do not use abrasive cleaners.

Item	Component Name	Qty
1	Bonnet Protector Set	1
2	Screw Plugs	3
	Self Tapping Screws	3
	Large Washers	3
	Small Screws	2
	Small Washers	2
	Nut Inserts	2
	Metal Wing Clips	2
	Abrasive Resistant Tape	2

-  x 3 SCREW PLUGS
 -  x 3 SELF TAPPING SCREWS
 -  x 3 LARGE WASHERS
 -  x 2 SMALL SCREWS
 -  x 2 SMALL WASHERS
 -  x 2 NUT INSERTS
 -  x 2 METAL WING CLIPS
 -  x 2 ABRASIVE RESISTANT TAPES
 -  TAPES
- FITTING KIT
10966

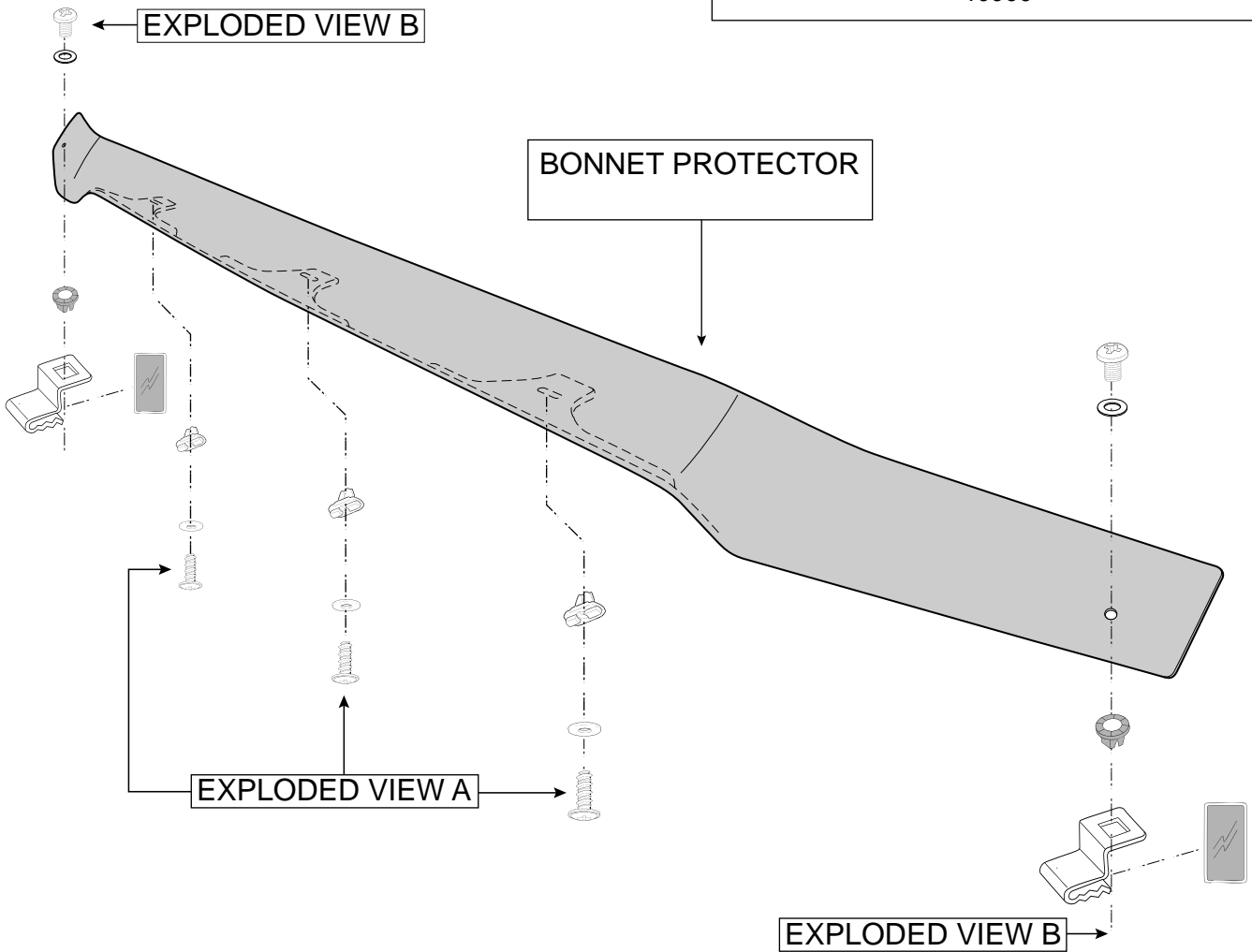

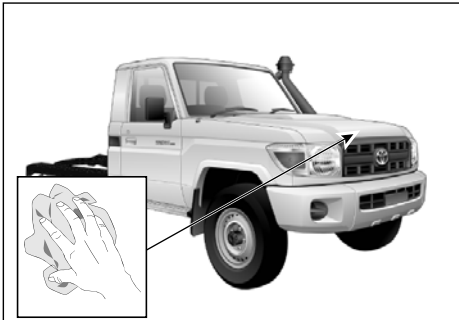
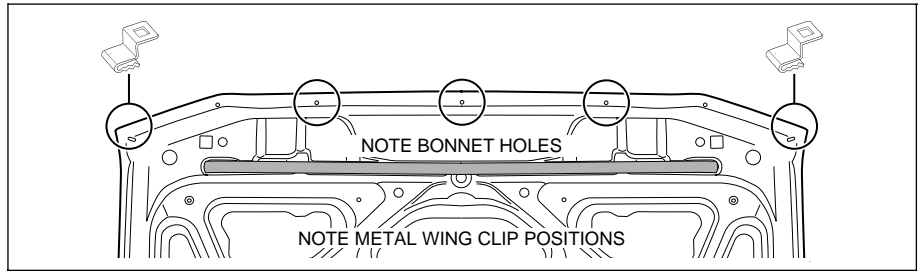

Diagram #: 1



1. Open & thoroughly clean and dry the bonnet. Trial fit Bonnet Protector centrally onto bonnet. Note the holes in the underside of the bonnet that correspond to the slots in the Bonnet Protector tags. Also note the metal wing clip positions, then mark these positions onto the bonnet with a pencil or non-permanent marker. Remove Bonnet Protector. **See Dia #1.**

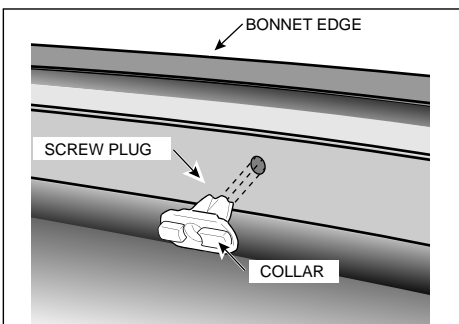

Diagram #: 2

2. Insert the screw plugs provided into the previously noted corresponding holes in the the underside of the bonnet. **See Dia #2.**

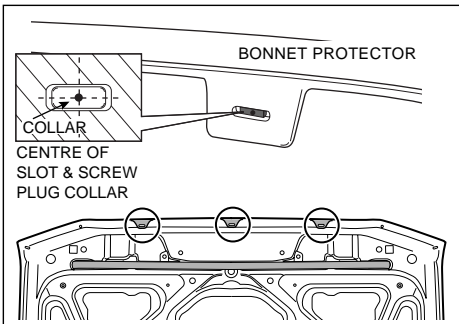

Diagram #: 3

3. Install the Bonnet Protector centrally onto bonnet. Ensure that the collar of the screw plugs locate into and parallel with the slots in the Bonnet Protector tags, as shown. **See Dia #3.**

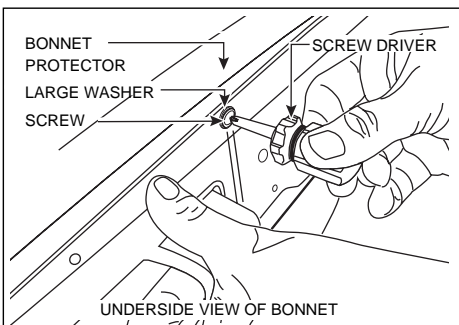

Diagram #: 4

4. While maintaining the thumb pressure against the underside of the Bonnet Protector, insert the self-tapping screw (with large washers) into screw plug and tighten screws. Do not fully tighten yet. Ensure the Bonnet Protector is centralised on bonnet then fully tighten screws. **See Dia #4.**
IMPORTANT: Thumb pressure must be maintained on the Bonnet Protector to prevent the screw plug from rotating. DO NOT OVERTIGHTEN SCREWS.

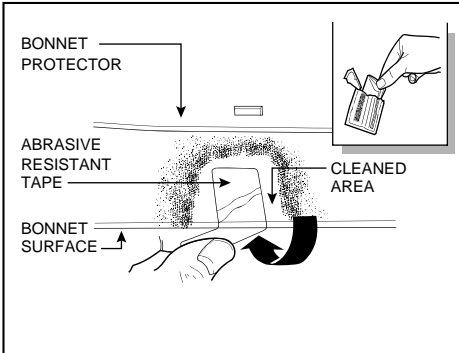

Diagram #:5

5. Clean the noted areas under the wing clip locations (see Dia #1) with alcohol wipe provided. Wipe off any residue with a dry clean cloth. Adhere the abrasive resistant tape strips over the bonnet lip. Apply tape so approximately half of each strip is adhered to the topside and half is adhered to the underside of bonnet. **See Dia #5.**

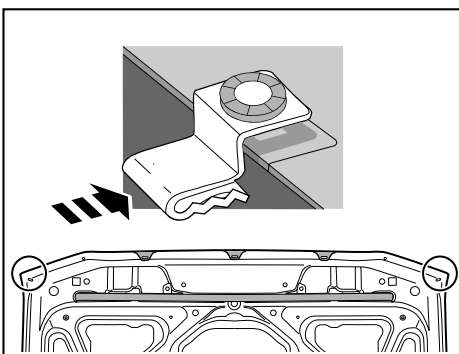

Diagram #:6

6. Fit the nut inserts into the square slots of the metal wing clips. Locate the metal wing clips over the abrasive resistant tape strips on the bonnet lip. **See Dia #6.**
IMPORTANT: Ensure that the clips are positioned over abrasive resistant tape and do not come in contact with any of the bonnet's paint work. Failure to do this may result in permanent paint damage.

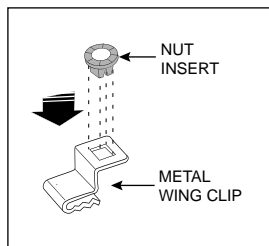

Diagram #:7

7. Secure the Bonnet Protector to the metal wing clips with the small screws and small washers provided. **See Dia #7.**
TO REMOVE: Reverse the above procedure.