

INSTALLATION GUIDE FOR BONNET PROTECTOR SUITABLE FOR ISUZU D-MAX 2021+

SKU: BP-DMAX-01

Please Note:

Please read these instructions carefully prior to installation. Check the contents of this kit before commencing fitment and report any discrepancies. Do not use power tools. Only tighten with hand tools to avoid stripping the bolt heads or cross threading the bolts. Prior to commencing the installation it is the installers responsibility to verify that all components are correct. Problems and losses which occur to improper installation and use are not covered by our warranty.

PARTS LIST:

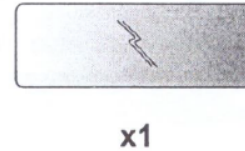
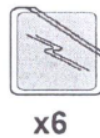
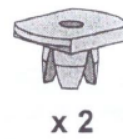
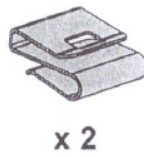
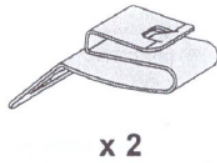
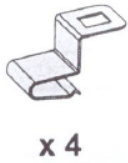
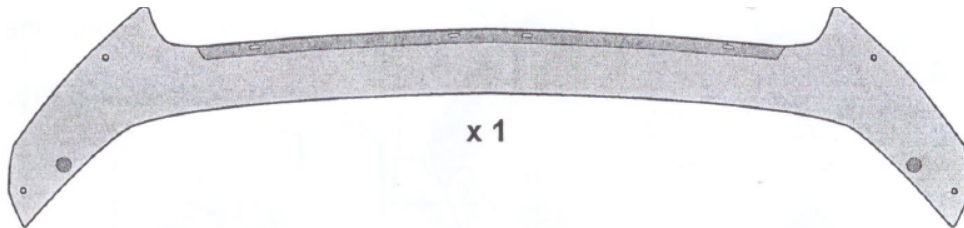

TOOLS REQUIRED (not supplied):



GENERAL CARE:

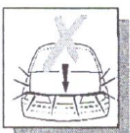

Do not slam bonnet.



Clean Bonnet Protectors with a mild detergent and water solution.



Do not use abrasive cleaners.

1. Read installation instructions thoroughly before commencing installation.
Open the bonnet and thoroughly clean and dry the bonnet and surrounding areas.

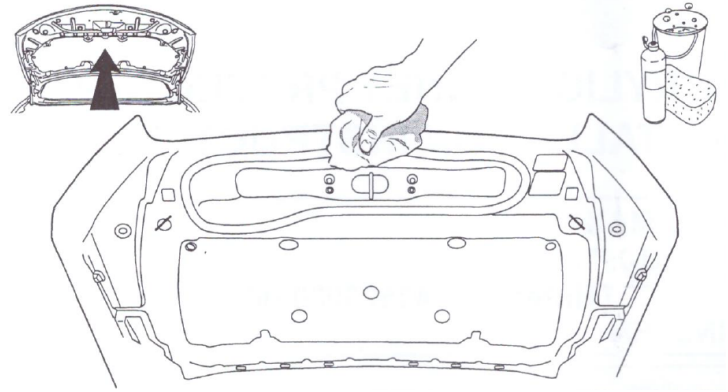

2. Trial fit bonnet protector centrally on the bonnet.

With a non-permanent marker, note the positions of the holes and slots in the bonnet protector and where they contact the bonnet surface.

Note the location of the centre acrylic tag and where it contacts the bonnet surface.

Remove the bonnet protector.

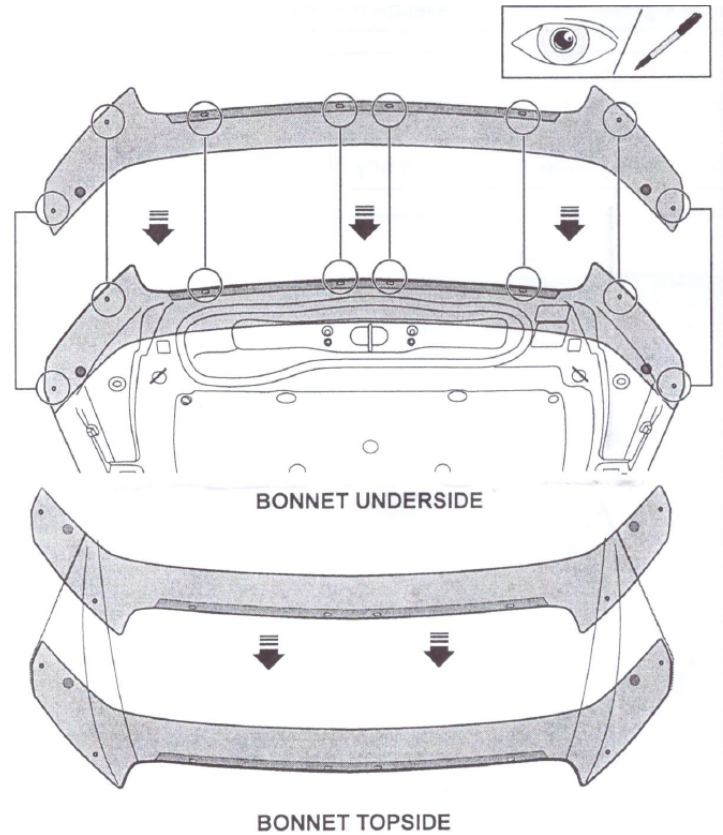

3. Clean the noted areas with the alcohol wipe provided. Allow to dry.

Adhere the eight medium abrasive resistant tapes over the bonnet lip.

Apply tape so approximately half of each strip is adhered to the top side and half is adhered to the underside of bonnet.

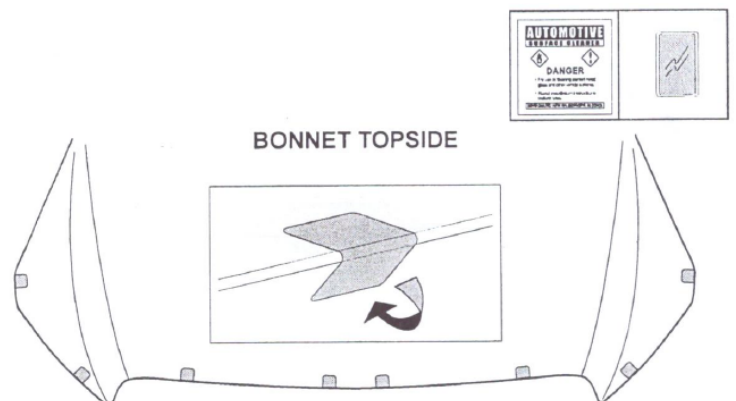

4. Sit the bonnet protector back from the front lip of the bonnet.

Clean the area of the bonnet that corresponds to the centre acrylic tag with the alcohol wipe provided. Allow to dry.

Adhere the long abrasive resistant tape strip flush with the front edge of the bonnet at each tag location.

5. Push the four clips onto the acrylic tag of the bonnet protector as shown. A definite click should be heard when the slot in the acrylic tag engages with the metal clip.

6. Re-install the bonnet protector. Ensure the bonnet protector is centrally located on the bonnet.

Ensure the metal clips are over the abrasion resistant tapes.

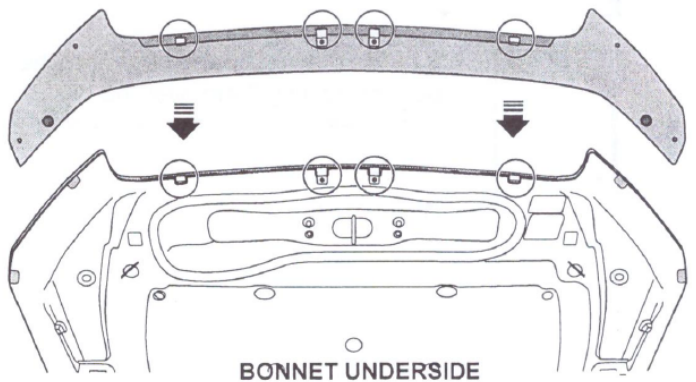
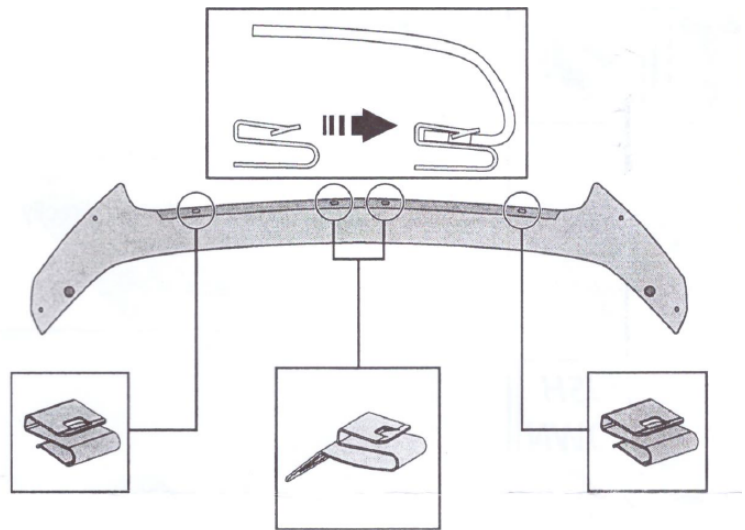
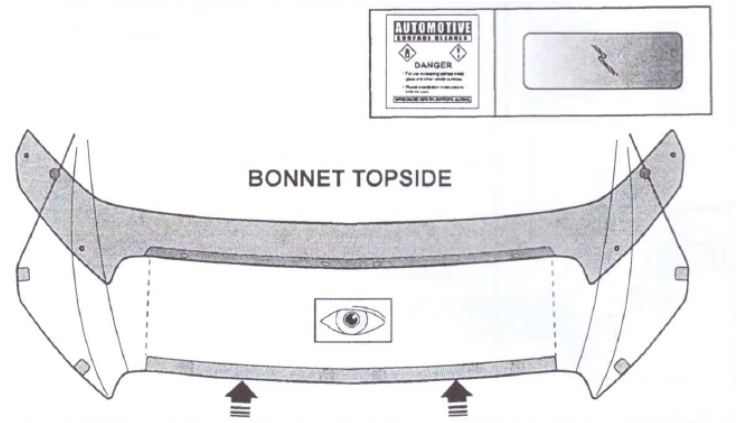

7. Adhere two small abrasive resistant tapes on the fixed clip, aligning it with the inner slots on the clip.

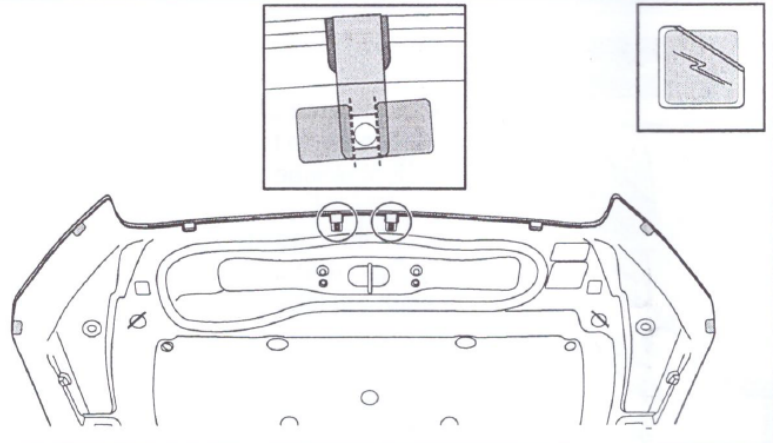

8. Ensure the bonnet protector is centrally located on the bonnet.

Secure the two centre metal clips and bonnet protector to the bonnet with the fastener and self tapping screws provided.

Ensure that clips are positioned directly over abrasive resistant tapes.

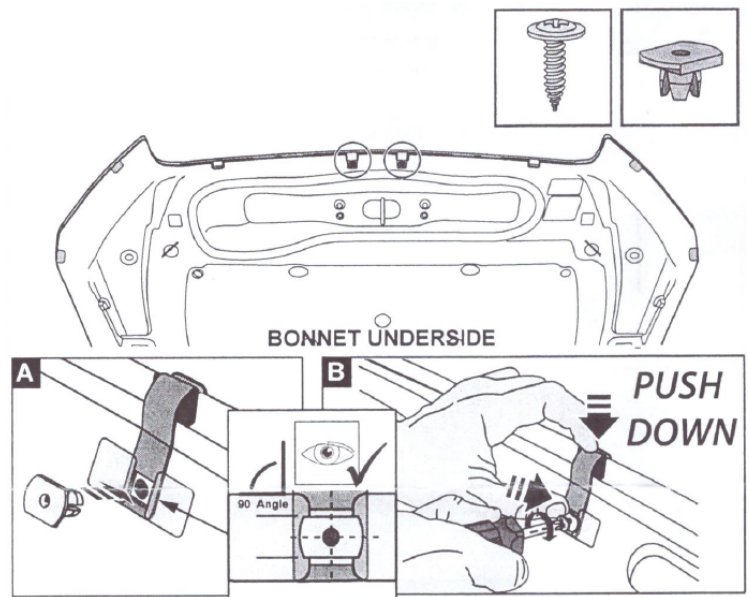

9. Slide the metal wing clips onto the bonnet locating them over the anti-abrasive tape strips as shown.

IMPORTANT: Ensure that the clips are positioned over abrasive resistant tape and do not come in contact with any of the bonnet's paint work. Failure to do this may result in permanent paint damage.

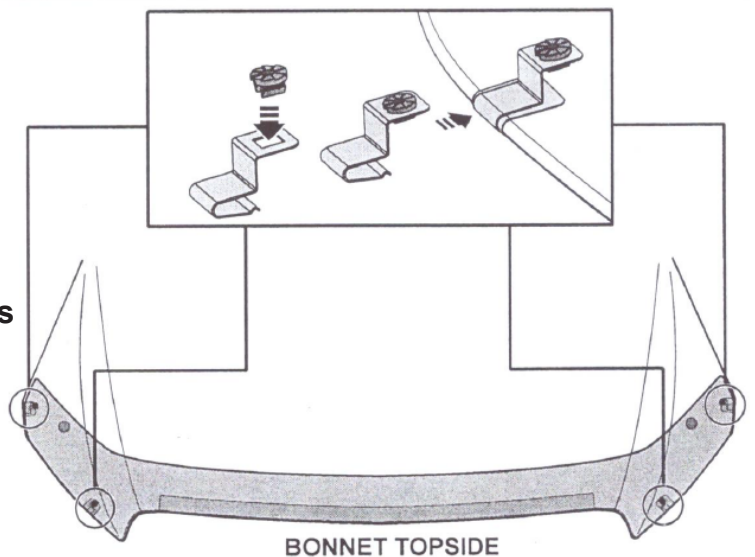

10. Secure the bonnet protector to the metal wing clips with the large screws and washers provided.

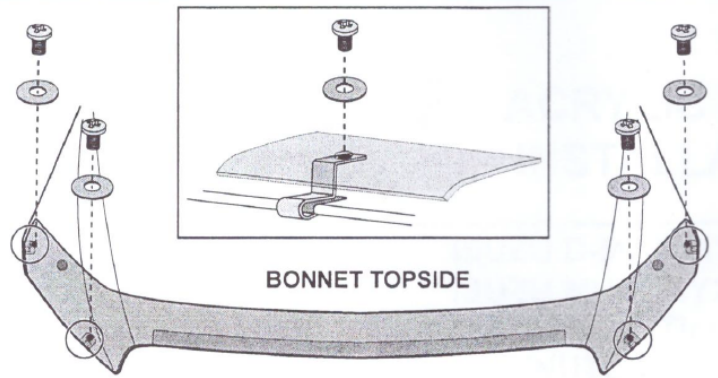

11. With a provided alcohol wipe, clean the bonnet under the indicated bumpons and apply a small abrasive resistant tape under each.

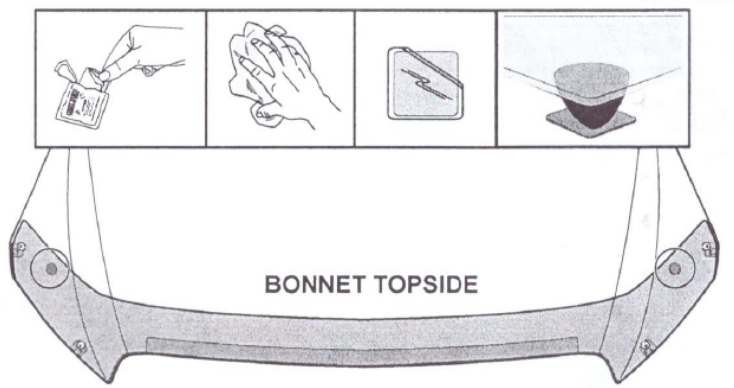

Re-check that your workmanship has been of the highest professional standard, then clean up the work area and ensure that the vehicle or accessory is not scratched or left dirty. Remove all tools, protective covers, waste materials, grease, dirt or grime from the work area.